

# Newark & Nottinghamshire Agricultural Society

A Company Limited by Guarantee Registered in England

**Certificate of Incorporation** 1716766

**Registered Charity** No 514080

**VAT Reg No** 651540162

**President:** Mr Frank A Reynolds MBE

**Chief Executive:** Mr A Johnston

---

## THE NOTTINGHAMSHIRE COUNTY SHOW 2017

Articles of Association, By-Laws & Regulations

The organisation of the Nottinghamshire County Show is under the control of a Council.

The Show is held under the Articles of Association, By-Laws and Regulations of the Newark & Nottinghamshire Agricultural Society, which accordingly binds all exhibitors and others attending the Show.

The attention of exhibitors is drawn to the Show Rules & Regulations (please see copy enclosed) and to the Breed Societies and conditions printed in the Schedule.

Copies of the Articles of Association, By-Laws and Regulations are obtainable on request from the Chief Executive.

The Society reserves the right to postpone or cancel the Show, or any particular section or event, if such cancellation, postponement arises out of strikes, lock-outs, trade disputes or labour problems, or any other cause beyond the control of the Society, including, but without limitation, Act of God, Governmental Act Regulation or request, fire, accident, war, riot or inability to obtain adequate labour, materials or sufficient number of entries.

The Schedule is issued subject to the Orders & Advice of DEFRA - The Department for Environment, Food & Rural Affairs, and any Local Authorities which may be operative at the time of the Show.

**Address:**

Newark & Nottinghamshire  
Agricultural Society  
Newark Showground  
Lincoln Road  
Newark  
Nottinghamshire  
NG24 2NY

---

**Twitter:**

@NottsCountyShow

---

**Facebook:**

Nottinghamshire  
County Show

---

**Website:**

[www.nottinghamshire  
countyshow.com](http://www.nottinghamshirecountyshow.com)

---

**Telephone:**

01636 705796

---

**Email:**

show@  
[newarkshowground.com](mailto:show@newarkshowground.com)

---

# FLORAL ART

**Judge:** Mrs Pat Hutchinson

---

**Open to all visitors on:**

Saturday 13th May, 10.30am to 5.30pm

Sunday 14th May, 9.00am to 5.00pm

---

**Staging:**

Will take place between 10.00am and 10.00pm on Friday 12th May. All exhibitors are asked to be in the Lady Eastwood Centre between these times to ensure their exhibit is arranged and in place by 10.00pm, ready for judging to commence on the Saturday morning.

---

**Judging:**

Will take place on Saturday 13th May commencing at 7.30am. The building will be cleared at 7.00am and no-one, other than the Judge and stewards in attendance, will be allowed in until judging has been completed. All exhibits will be judged in accordance with the NAFAS Competitions Manual Third Edition 2015.

---

**Prizes:**

Classes 959 - 965:           **1st £20    2nd £15    3rd £10**

Classes 958 & 961:       **1st £50    2nd £35    3rd £20**

---

**Entry:**

FREE entry in all classes except Class 959

Class 959 (Imposed Exhibit): £16.00 entry fee

Any Exhibitor who cannot attend Staging Day please notify NNAS by phoning 01636 705796 by Thursday 11th May

**Note:** Measurements are given for each class and in all cases are: Width x Depth x Height unless otherwise stated. All measurements are approximate.

**COLOUR OF STAGING BACKGROUND, DRAPES & PLINTHS FOR ALL CLASSES WILL BE BLACK, UNLESS OTHERWISE STATED**

# Theme: Images

## 958 Hot & Cold

An exhibit

**Space allowed:** width 152cm, depth 122cm, height optional

**Staging - a base -** width 152cm, depth 122cm, height 13cm

Judged from the front but viewed all round

This class is open to be shared by a maximum of TWO persons only. Allowance towards class expenses £25 to be given on staging day. The winner of this class will receive ***The Peggy Lawrence Trophy.***

---

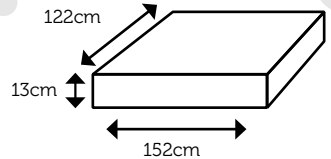

## 959 Something Different!

An imposed exhibit

**Space allowed:** width 92cm, depth 68cm, height 107cm

**Staging -** tabling with backing

All components will be provided.

Competitors may use ALL or SOME of the components unless otherwise stated. Tools allowed - scissors/secateurs/knife ONLY. Class to commence at 3.30pm, finish 5pm on staging day Friday 12th May. Exhibitors must be in place to start their exhibit at the same time. ALL components to be taken home after dismantling on Sunday 14th May

Maximum number of entries 16.

---

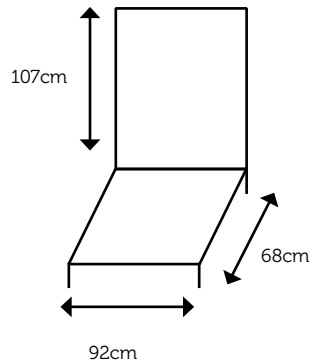

## 960 Take the Rough with the Smooth

An exhibit featuring foliage

**Space allowed:** width 92cm, depth 68cm, height 107cm

**Staging -** tabling with backing

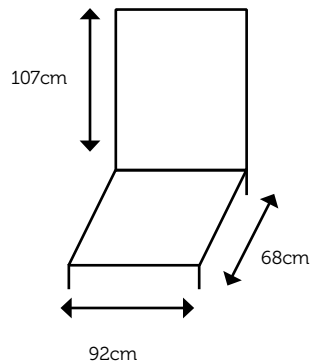

**961 Diversity**  
An exhibit

**Space allowed:** width 122cm, depth 107cm, height optional

**Staging -** a base - width 122cm, depth 107cm, height 30cm

Judged from the front but viewed all round

Allowance towards class expenses £20 to be given on staging day. The winner of this class will receive *The Oaklands Nurseries Perpetual Challenge Cup.*

---

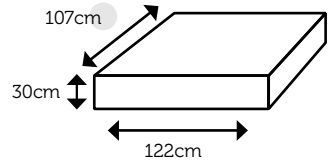

**962 Life's Ups & Downs!**  
An exhibit

**Staging -** circular tables covered in pale green fabric. Overhang from the table is not allowed

**Table size -** diameter 107cm, height from floor 76cm, exhibit height optional

Viewed and judged all round

Maximum number of entries 10

---

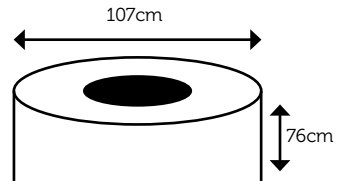

**963 From the Darkness to Light**  
A contemporary exhibit

**Space allowed:** width 75cm, depth 50cm, height 180cm

**Staging -** black painted metal grid stand on a pole. Mesh size 5cm<sup>2</sup>

**Grid size -** height 88cm, width 58cm

No base placements allowed

Judged from the front but viewed all round

Maximum number of entries 10

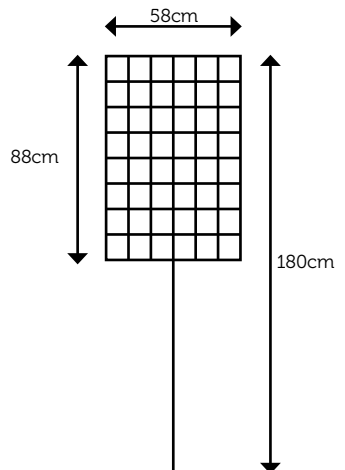

**964 Conceal & Reveal**

An exhibit

**Space allowed:** width 120cm, depth 120cm, height 40cm

**Staging -** on grey concrete floor

Viewed and judged all round

The space allowed will be marked out on the floor.  
Competitors may provide their own floor covering or base.

---

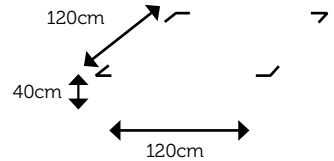

**965 Less is More**

A petite exhibit

**Space allowed:** width 25cm, depth 25cm, height 37cm

**Staging -** exhibits will be staged on 25cm display cubes on open tabling

Judged from the front but viewed all round

Exhibits may be brought pre-done. The winner of the Class will receive **The Cicely Mould Memorial Award**

---

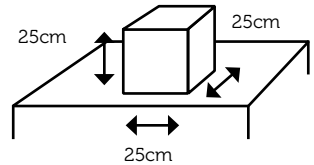

**966 Contrasts**

An exhibit

**Space allowed:** width 68cm, depth 68cm, height optional

**Staging -** open tabling - ON 30CM DIAMETER FOAM BASED WREATH RING PROVIDED

Viewed and judged all round

This is a novice class for those who have NOT won a first prize at any Show prior to date of entry. The winner will receive **The Jill Lewis Prize**

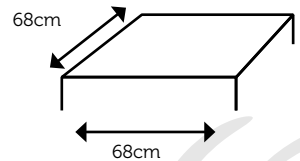

# BEST IN SHOW AND SPECIAL AWARDS

## **Best Exhibit in Show**

The Newark & District Horticultural Society Perpetual Challenge Trophy. To be competed for by the 1st prize winners from Classes 958 - 966

---

## **Runner-up to Best Exhibit in Show**

The Ian Buxton Cup

---

## **The Exhibit which emphasises the best use of colour**

The Winthorpe Perpetual Award

---

## **The Exhibit which best emphasises the use of garden plant material**

The Newark Flower Lovers Perpetual Trophy

---

## **The Exhibit winning first prize in the Petite Class 965**

The Cicely Mould Memorial Award

---

## **Exhibitor gaining the most points in the Floral Art Section**

The Kilvington Perpetual Rose Bowl

---

In the event of equality of points the trophy will be shared and any accompanying prizes in kind will be withheld.

---

Points will be awarded as follows;

**1st - 3 points,**

**2nd - 2 points,**

**3rd - 1 point**

In the event of a tie, the winner will be determined by establishing which exhibitor has won the most first prizes in the section, or, if necessary, by the exhibitor having won the most second prizes in the section and so on.

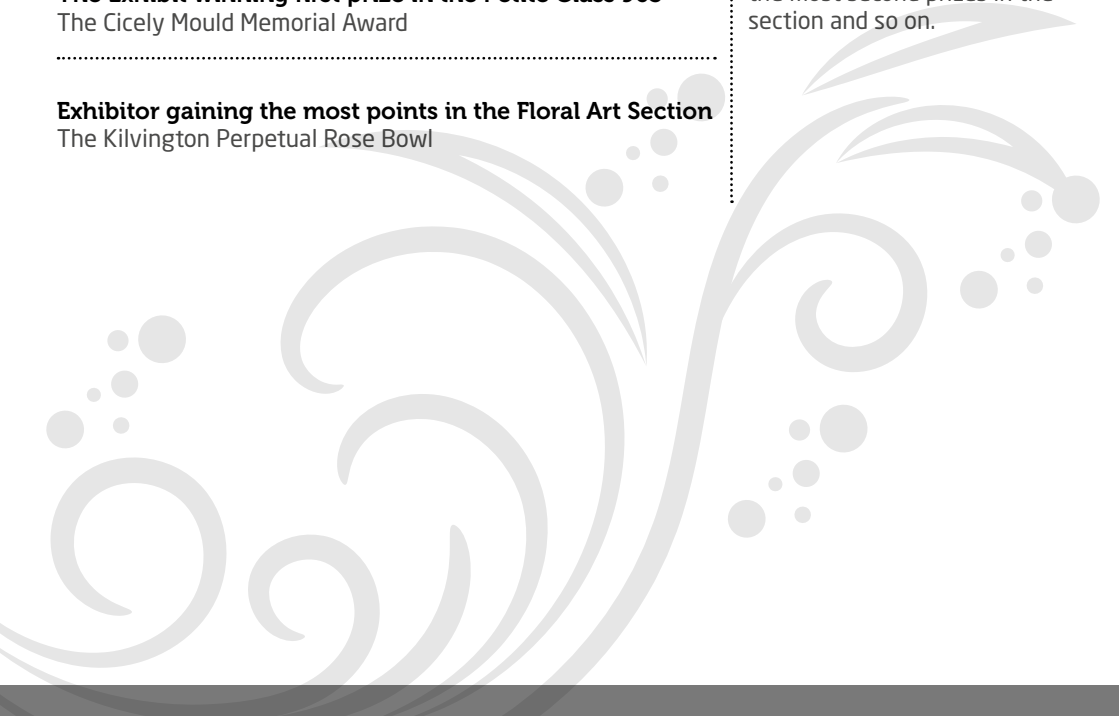
A large, stylized, light grey floral graphic is positioned in the bottom right corner of the page. It features elegant, swirling lines that resemble stems and leaves, interspersed with various sized circles and dots, creating a decorative and organic feel.

# FLORAL ART RULES & CONDITIONS

1. An exhibit is composed of natural plant material in all its' forms, with or without accessories, contained within a space as specified in the show schedule. Schedule 'definitions' state that disqualification will take place for the following reasons:
    - a. Failure to comply with any specific requirement of a class as stated in the show schedule, i.e. measurements or components.
    - b. Inclusion of any fresh plant material which does not have the roots or the cut ends of stems in water or water retaining material (for exclusions see the NAFAS Competitions Manual Third Edition 2015).
    - c. Inclusion of artificial plant material (unless specifically allowed by the Show schedule).

---
  2. Classes 958 - 966 will be judged in accordance with the NAFAS Competition Manual Third Edition 2015.

The Show will be subject to the rules and regulations of the Newark & Nottinghamshire Agricultural Society (NNAS) where applicable.

Once judging has been completed no exhibit may be touched without permission from the stewards of the Show.

---
  3. Staging may commence from 10am on Friday 12th May and must be completed by 10.00pm on Friday 12th May 2017. Exhibitors must only take spaces which have been allocated to them.

---
  4. The Show reserves the right to substitute judges other than those announced in the Schedule and/or catalogue for any who may be unavoidably prevented from attending and also to make additional appointments. All entries are accepted on this understanding. There can be no refund of entry fees where a substitution or addition has been made.

---
  5. The Judge's decision shall be final.

---
  6. An entry form is enclosed. This must be completed and returned, accompanied by the remittance, no later than Friday 14th April 2017.

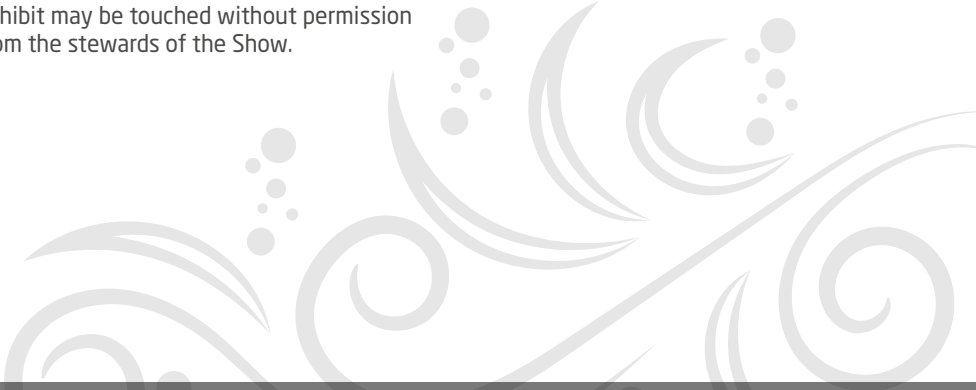
---
  7. Cheques are payable to NNAS. Credit/ Debit card payments are acceptable.
- 

8. Entry fees cannot be returned.

---

9. All entries must be the unaided work of the competitor and must be assembled at the Showground, except where otherwise stated in the Schedule. Many techniques, whether contemporary or traditional, require a great deal of time to complete. Pre-done work of this type is acceptable in any class, unless specifically excluded by the Show Schedule. Only one person may make each entry and must not receive any help from another person. If drapes are used they must be supported by stands provided by exhibitors. No extra skirting will be allowed over the side of tabling. Nothing may be attached to the background unless specifically permitted. The name and address of the exhibitor must be securely attached to the base of all containers.

---

10. Pre-Show passes will be required for admission to the Showground on the days prior to the Show and will be allocated with the exhibitor's tickets.

Each exhibitor will be allocated weekend passes to the Showground valid for 2 persons for both days of the Show.

---

11. The exhibits will remain at the sole risk of the exhibitor. The NNAS cannot be held responsible for any loss or damage however caused or occasioned. It is therefore recommended that exhibitors hold an insurance policy.

12. No exhibit may be dismantled or removed before 5.30pm on Sunday 14th May. No vehicle will be allowed onto the showground before 6pm

---

13. Challenge Cups and Trophies are fully insured by NNAS and may be collected from the Floral Art Stewards' area situated in the Exhibition Hall. They will not be dispatched after the Show. Exhibitors are required to return cups and trophies in good condition, at their own expense when requested to do so. Engraving of winner's names has been discontinued and exhibitors are forbidden to have any cup or trophy engraved. It is regretted that anyone who ignores this ruling will be fined a substantial sum for each cup or trophy to cover the cost of restitution.

---

14. Prize money to be collected from the ICE cash payment office on site on the days of the Show or can be claimed by returning the prize slips to the Society within one month after the Show.

