

Newark & Nottinghamshire Agricultural Society

A Company Limited by Guarantee Registered in England

Certificate of Incorporation 1716766

Registered Charity No 514080

VAT Reg No 651540162

President: Mr Charles Szabo

Chief Executive: Mr A Johnston

THE NOTTINGHAMSHIRE COUNTY SHOW 2019

Articles of Association, By-Laws & Regulations

The organisation of the Nottinghamshire County Show is under the control of a Council.

The Show is held under the Articles of Association, By-Laws and Regulations of the Newark & Nottinghamshire Agricultural Society, which accordingly binds all exhibitors and others attending the Show.

The attention of exhibitors is drawn to the Show Rules & Regulations (please see copy enclosed) and to the Breed Societies and conditions printed in the Schedule.

Copies of the Articles of Association, By-Laws and Regulations are obtainable on request from the Chief Executive.

The Society reserves the right to postpone or cancel the Show, or any particular section or event, if such cancellation, postponement arises out of strikes, lock-outs, trade disputes or labour problems, or any other cause beyond the control of the Society, including, but without limitation, Act of God, Governmental Act Regulation or request, fire, accident, war, riot or inability to obtain adequate labour, materials or sufficient number of entries.

The Schedule is issued subject to the Orders & Advice of DEFRA - The Department for Environment, Food & Rural Affairs, and any Local Authorities which may be operative at the time of the Show.

Address:

Newark & Nottinghamshire
Agricultural Society
Newark Showground
Lincoln Road
Newark
Nottinghamshire
NG24 2NY

Twitter:

@NottsCountyShow

Facebook:

Nottinghamshire
County Show

Website:

www.nottinghamshirecountyshow.com

Telephone:

01636 705796

Email:

show@
[newarkshowground.com](mailto:show@newarkshowground.com)

FLORAL ART

Judge: Mrs Margaret Rumens

Open to all visitors on:

Saturday 11th May, 10.30am to 5.30pm

Sunday 12th May, 9.00am to 5.00pm

Staging:

Will take place between 10.00am and 10.00pm on Friday 10th May. All exhibitors are asked to be in the Lady Eastwood Centre between these times to ensure their exhibit is arranged and in place by 10.00pm, ready for judging to commence on the Saturday morning.

Judging:

Will take place on Saturday 11th May commencing at 7.30am. The building will be cleared at 7.00am and no-one, other than the Judge and stewards in attendance, will be allowed in until judging has been completed. All exhibits will be judged in accordance with the NAFAS Competitions Manual Third Edition 2015.

Prizes:

Classes 959 - 966: **1st £20, 2nd £15, 3rd £10**

Classes 958 & 961: **1st £50, 2nd £35, 3rd £20**

Entry:

FREE entry in all classes except Class 959

Class 959 (Imposed Exhibit): £16.00 entry fee

Any Exhibitor who cannot attend Staging Day please notify NNAS by phoning 01636 705796 by Thursday 9th May

Note: Measurements are given for each class and in all cases are: Width x Depth x Height unless otherwise stated. All measurements are approximate.

**COLOUR OF STAGING
BACKGROUND, DRAPES &
PLINTHS FOR ALL CLASSES
WILL BE BLACK, UNLESS
OTHERWISE STATED**

Theme: The Elements

958 The Elements

An exhibit

Space allowed: width 152cm, depth 122cm, height optional

Staging - a base - width 152cm, depth 122cm, height 13cm
Judged from the front but viewed all round

This class is open to be shared by a maximum of TWO persons only. Allowance towards class expenses £30 to be given on staging day. The winner of this class will receive **The Peggy Lawrence Trophy**.

Maximum number of entries 8.

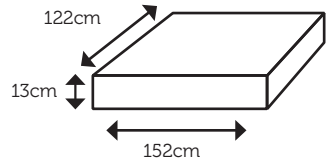

959 Fruits Of The Earth

An imposed exhibit

Space allowed: width 90cm, depth 68cm, height optional

Staging - tabling with backing height 107cm

All components will be provided.

Competitors may use ALL or SOME of the components unless otherwise stated. Tools allowed - scissors/secateurs/knife ONLY. Class to commence at 3.00pm, finish 5pm on staging day Friday 10th May. Exhibitors must be in place to start their exhibit at the same time. ALL components to be taken home after dismantling on Sunday 12th May.

Maximum number of entries 15.

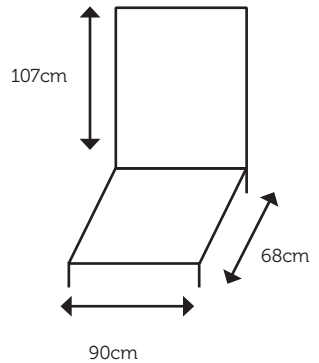

960 Earthly Delights

An exhibit featuring foliage

Space allowed: width 90cm, depth 68cm, height optional

Staging - tabling with backing height 107cm

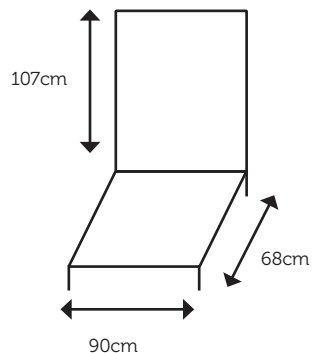

961 All At Sea

A seascape exhibit

Space allowed: width 122cm, depth 107cm, height 60cm

Staging - a base - width 122cm, depth 107cm, height 30cm

Viewed and judged all round. Max number of entries 6.

The winner of this class will receive **The Oaklands Nurseries Perpetual Challenge Cup.**

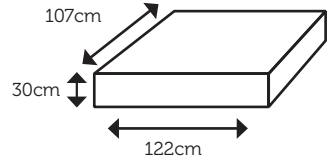

962 Come Rain Or Shine

A pedestal exhibit

Space allowed: width 120cm, depth 120cm, height optional

Staging - on grey concrete floor

The space allowed will be marked out on the floor. Competitors may provide own floor covering or base. Competitor to provide own pedestal.

Judged from the front but viewed all round.

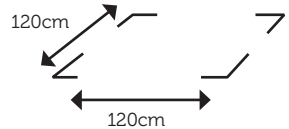

963 Floating On Air

A contemporary exhibit

Space allowed: width 90cm, depth 68cm, height optional

Staging - tabling with backing height 107cm

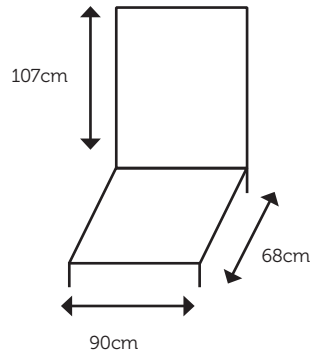

964 Fired Up
An exhibit

Space allowed: width 50cm, depth 50cm, height optional.

Staging - a base - width 50cm, depth 50cm, height 50cm.

Viewed and judged all round

Max number of entries 14

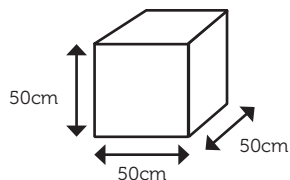

965 Earth's Treasures
A petite exhibit

Space allowed: width 25cm, depth 25cm, height optional.

Staging - exhibits will be staged on 25cm display cubes on open tabling

Judged from the front but viewed all round. Max number of entries 18. Exhibits may be brought pre-done. The winner of the Class will receive **The Cicely Mould Memorial Award**

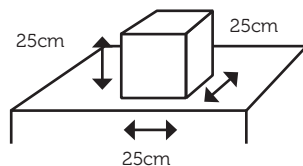

966 Ball Of Fire
An exhibit

Space allowed: width 68cm, depth 68cm, height optional

Staging - open tabling

Judged from the front but viewed all round. This is a NOVICE class for those who have NOT won a first prize at any Show prior to date of entry. The winner of this class will receive **The Jill Lewis Shield**

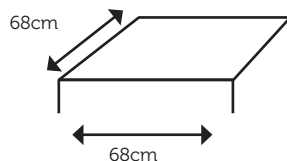

BEST IN SHOW AND SPECIAL AWARDS

Best Exhibit in Show

The Newark & District Horticultural Society Perpetual Challenge Trophy. To be competed for by the 1st prize winners from Classes 958 - 966

Runner-up to Best Exhibit in Show

The Ian Buxton Cup

The Exhibit which emphasises the best use of colour

The Winthorpe Perpetual Award

The Exhibit which best emphasises the use of garden plant material

The Newark Flower Lovers Perpetual Trophy

The Exhibit winning first prize in the Petite Class 965

The Cicely Mould Memorial Award

The Exhibit winning first prize in the Novice Class 966

The Jill Lewis Shield

Exhibitor gaining the most points in the Floral Art Section

The Kilvington Perpetual Rose Bowl

In the event of equality of points the trophy will be shared and any accompanying prizes in kind will be withheld.

Points will be awarded as follows;

1st - 3 points,

2nd - 2 points,

3rd - 1 point

In the event of a tie, the winner will be determined by establishing which exhibitor has won the most first prizes in the section, or, if necessary, by the exhibitor having won the most second prizes in the section and so on.

FLORAL ART RULES & CONDITIONS

1. An exhibit is composed of natural plant material in all its' forms, with or without accessories, contained within a space as specified in the show schedule. Schedule 'definitions' state that disqualification will take place for the following reasons:
 - a. Failure to comply with any specific requirement of a class as stated in the show schedule, i.e. measurements or components.
 - b. Inclusion of any fresh plant material which does not have the roots or the cut ends of stems in water or water retaining material (for exclusions see the NAFAS Competitions Manual Third Edition 2015).
 - c. Inclusion of artificial plant material (unless specifically allowed by the Show schedule).
2. Classes 958 - 966 will be judged in accordance with the NAFAS Competition Manual Third Edition 2015.

The Show will be subject to the rules and regulations of the Newark & Nottinghamshire Agricultural Society (NNAS) where applicable.

Once judging has been completed no exhibit may be touched without permission from the stewards of the Show.
3. Staging may commence from 10am on Friday 10th May and must be completed by 10.00pm on Friday 10th May 2019. Exhibitors must only take spaces which have been allocated to them.
4. The Show reserves the right to substitute judges other than those announced in the Schedule and/or catalogue for any who may be unavoidably prevented from attending and also to make additional appointments. All entries are accepted on this understanding. There can be no refund of entry fees where a substitution or addition has been made.
5. The Judge's decision shall be final.
6. All entries must be made via the online entry system, no later than Friday 12th April 2019. Competitors may only enter ONE EXHIBIT per class.
7. Cheques are payable to NNAS. Credit/ Debit card payments are acceptable.
8. Entry fees cannot be returned.
9. All entries must be the unaided work of

the competitor and must be assembled at the Showground, except where otherwise stated in the Schedule. Many techniques, whether contemporary or traditional, require a great deal of time to complete. Pre-done work of this type is acceptable in any class, unless specifically excluded by the Show Schedule. Only one person may make each entry and must not receive any help from another person. If drapes are used they must be supported by stands provided by exhibitors. No extra skirting will be allowed over the side of tabling. Nothing may be attached to the background unless specifically permitted. The name and address of the exhibitor must be securely attached to the base of all containers.

10. Pre-Show passes will be required for admission to the Showground on the days prior to the Show and will be allocated with the exhibitor's tickets. Each exhibitor will be allocated weekend passes to the Showground valid for 2 persons for both days of the Show.

11. The exhibits will remain at the sole risk of the exhibitor. The NNAS cannot be held responsible for any loss or damage however caused or occasioned. It is therefore recommended that exhibitors hold an insurance policy.

12. No exhibit may be dismantled or removed before 5.30pm on Sunday 12th May. No vehicle will be allowed onto the showground before 6pm

13. Challenge Cups and Trophies are fully insured by NNAS and may be collected from the Floral Art Stewards' area situated in the Exhibition Hall. They will not be dispatched after the Show. Exhibitors are required to return cups and trophies in good condition, at their own expense when requested to do so. Engraving of winner's names has been discontinued and exhibitors are forbidden to have any cup or trophy engraved. It is regretted that anyone who ignores this ruling will be fined a substantial sum for each cup or trophy to cover the cost of restitution.

14. Prize money to be collected from the cash payment office on site on the days of the Show or can be claimed by returning the prize slips to the Society within one month after the Show.
